

BRAKE TYPE HAB-2-90

HYDRAULIC APPLIED BRAKE

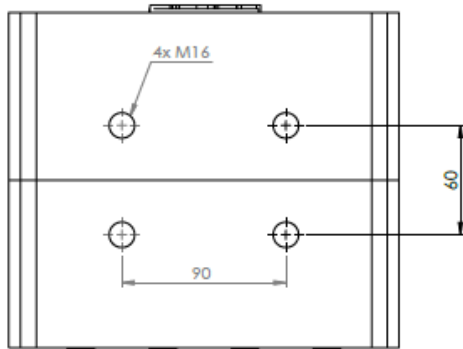
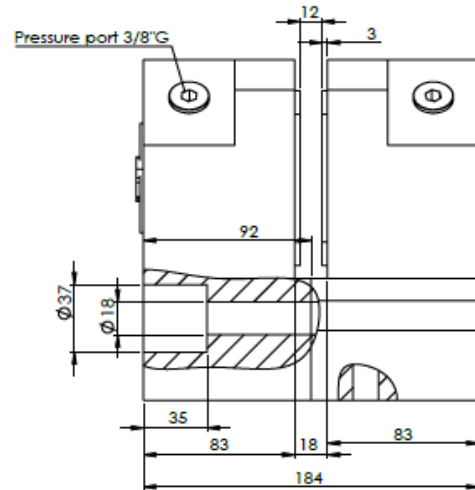
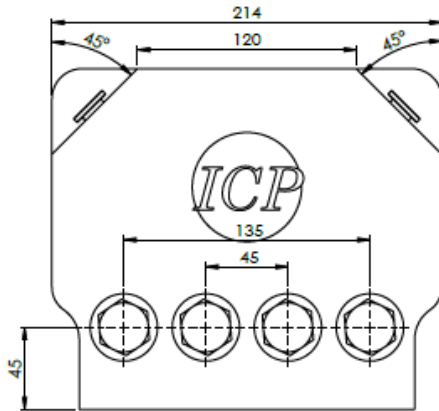

Description

HAB-2-90 is a hydraulic applied brake suitable for dynamic or static applications.

HAB-2-90 is compact in design with two opposed calipers. Manufactured to extremely tight tolerances to ensure zero oil leakage.

Can be installed in horizontal or vertical orientation.

Main features

- Hydraulic applied brake.
- Compact and robust design.
- Easy maintenance.
- Organic, asbestos free linings.
- Dual piston design.
- Long service life.
- Protection C4-H, according ISO 12944-2
- Reactive humidity $\leq 70\%$
- Suitable for low temperature applications.

BRAKE TYPE HAB-2-90

HYDRAULIC APPLIED BRAKE

Piston area (mm ²)	6361
Organic pad area (mm ²)	14,673
Max. wear of organic pad (mm)	7
Friction coefficient (μ)	0.4
Operating pressure (Mpa or N/mm ²)	12.5
Max. working pressure (Mpa or N/mm ²)	14
Total piston area (mm ²)	6361 (each half caliper)
Volume for each caliper at 1 mm stroke (mm ³)	6361
Max. clamping force (N)	79,521 (each half caliper)
Max. braking force (N)	63,616
Brake disc thickness (mm)	20 - 40
Pressure connection/port	3/8" G BSP
Recommended pipe size (mm)	10/8
Mounting bolts	M16 Quality 10.9 & 12.9
Operating temperature (°C)	-30 to +60

Assembly with the Rotor Brake:

$$\text{Brake Torque} = \mu \times \text{Clamping Force} \times R' (\text{N} * \text{mm})$$

$$R' = \text{Effective radius} = R - d (\text{mm})$$

