

BRAKE TYPE HAB-4-75

HYDRAULIC APPLIED BRAKE

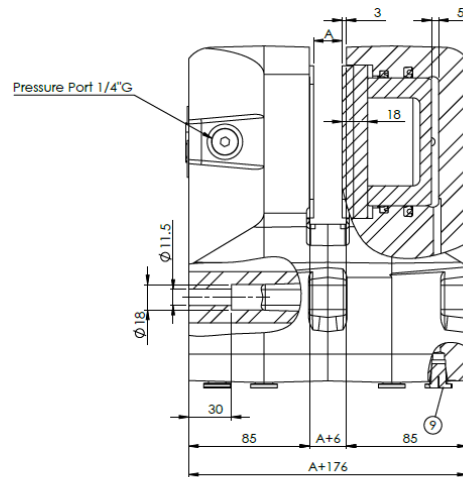
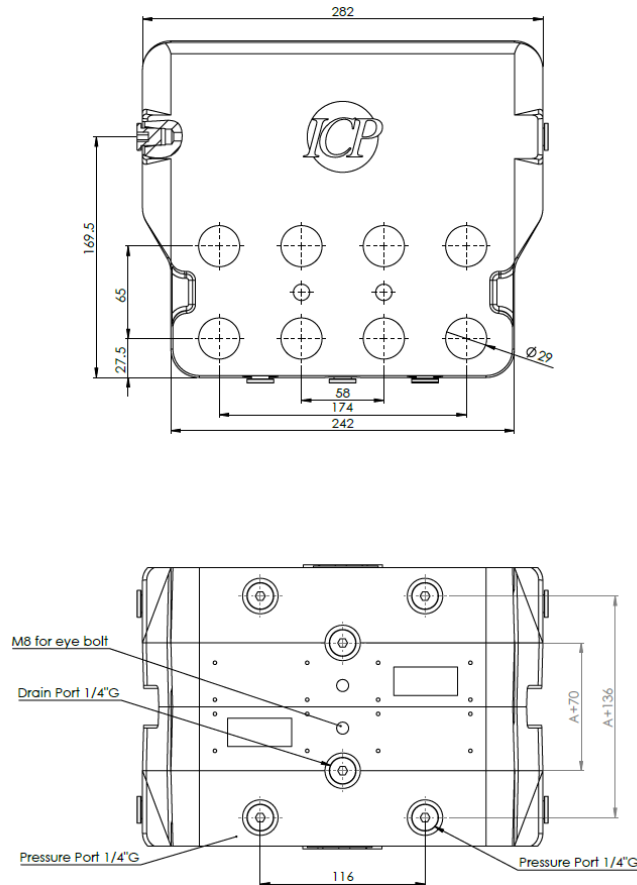

Description

HAB-4-75 is a hydraulic applied brake suitable for dynamic or static applications.

HAB-4-75 is a compact design with two pistons in each opposed caliper. Can be installed in horizontal or vertical orientation.

Main features

- Hydraulic applied brake.
- Compact and robust construction and design.
- Easy maintenance.
- Organic, asbestos free linings.
- Stainless steel pistons.
- Long service life.
- Protection C4-H, according ISO 12944-2
- Reactive humidity $\leq 70\%$

BRAKE TYPE HAB-4-75

HYDRAULIC APPLIED BRAKE

Max. Braking Force (N)	113100
Operating pressure (Mpa or N/mm ²)	16
Piston Area (mm ²)	4418
Pad area (mm ²)	19589
Max. wear of pad (mm)	7
Friction coefficient (μ)	0.4
Max working pressure (Mpa or N/mm ²)	18
Total piston area: each caliper half (mm ²)	8835
Volume for each caliper at 1 mm stroke (mm ³)	8835
Brake Disc thickness (mm)	20 - 40
Pressure connection/port	1/4" BSP
Drain connection/port	1/4" BSP
Recommended pipe size (mm)	10/8
Mounting Bolts	M24 and M27 Quality 10.9 and 12.9
Operating temperature (°C)	-30 to +60

Assembly with the Rotor Brake:

$$\text{Brake Torque} = \mu \times \text{Clamping Force} \times R' \text{ (N * mm)}$$

$$R' = \text{Effective radius} = R - d \text{ (mm)}$$

